

# PRODUCT INFORMATION PACKET

Model No: 184TTFW16013

Catalog No: C238C

7.50 HP General Purpose Motor, 3 phase, 3600 RPM, 208-230/460 V, 184TC Frame, TEFC  
Three Phase TEFC Motors



Regal and Marathon are trademarks of Regal Beloit Corporation or one of its affiliated companies.  
©2020 Regal Beloit Corporation, All Rights Reserved. MC017097E

**REGAL**



**Nameplate Specifications**

Output HP	<b>7.50 Hp</b>	Output KW	<b>5.6 kW</b>
Frequency	<b>60 Hz</b>	Voltage	<b>208-230/460 V</b>
Current	<b>19.2-17.6/8.8 A</b>	Speed	<b>3510 rpm</b>
Service Factor	<b>1</b>	Phase	<b>3</b>
Efficiency	<b>90.1 %</b>	Power Factor	<b>88.4</b>
Duty	<b>Continuous</b>	Insulation Class	<b>F</b>
Design Code	<b>A</b>	KVA Code	<b>L</b>
Frame	<b>184TC</b>	Enclosure	<b>Totally Enclosed Fan Cooled</b>
Thermal Protection	<b>No</b>	Ambient Temperature	<b>40 °C</b>
Drive End Bearing Size	<b>6206</b>	Opp Drive End Bearing Size	<b>6205</b>
UL	<b>Recognized</b>	CSA	<b>Y</b>
CE	<b>Y</b>	IP Code	<b>43</b>

**Technical Specifications**

Electrical Type	<b>Squirrel Cage Induction Run</b>	Starting Method	<b>Across The Line</b>
Poles	<b>2</b>	Rotation	<b>Reversible</b>
Resistance Main	<b>1.3 Ohms</b>	Mounting	<b>Round</b>
Motor Orientation	<b>Horizontal</b>	Drive End Bearing	<b>Ball</b>
Opp Drive End Bearing	<b>Ball</b>	Frame Material	<b>Rolled Steel</b>
Shaft Type	<b>T</b>	Overall Length	<b>15.97 in</b>
Frame Length	<b>10.50 in</b>	Shaft Diameter	<b>1.125 in</b>
Shaft Extension	<b>2.88 in</b>	Assembly/Box Mounting	<b>F1 ONLY</b>
Connection Drawing	<b>005010.01ME</b>	Outline Drawing	<b>035570-1050</b>

This is an uncontrolled document once printed or downloaded and is subject to change without notice. Date Created:06/11/2020

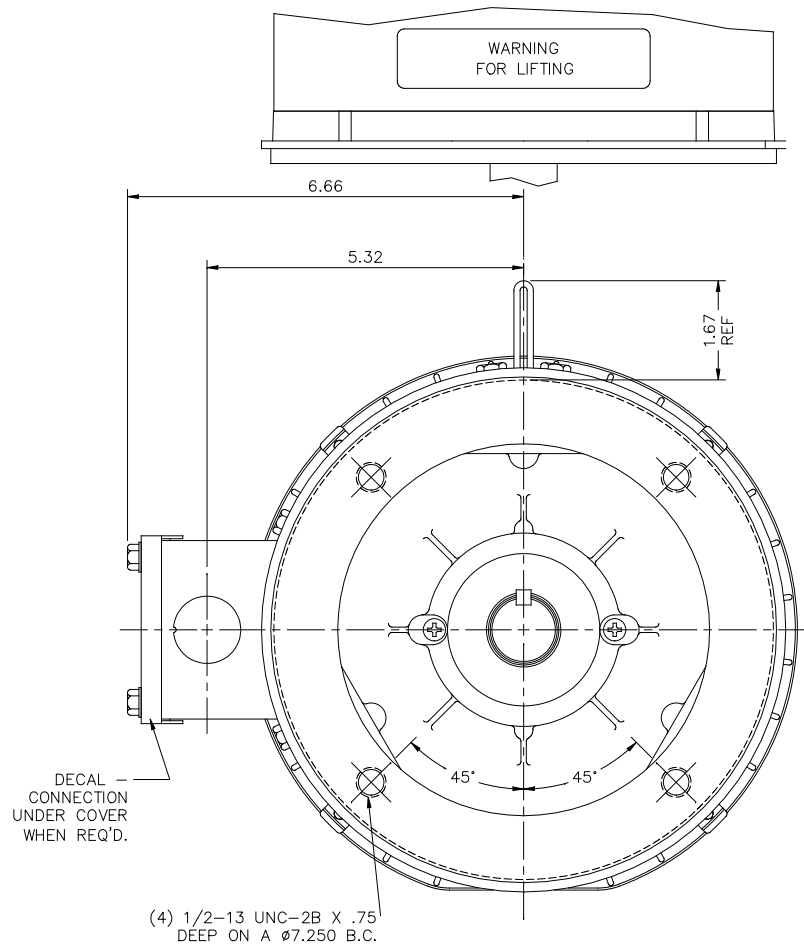
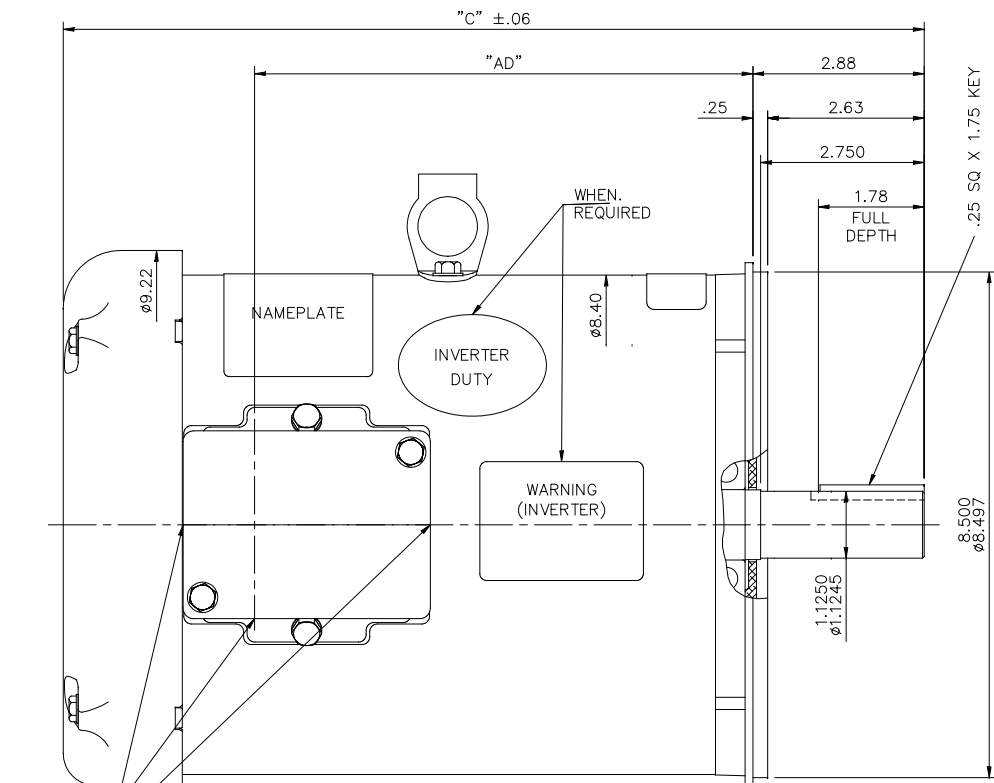

GASKETS THROUGHOUT  
 MAXIMUM FACE RUNOUT TO BE .004 T.I.R.  
 MAXIMUM PILOT ECCENTRICITY TO BE .004 T.I.R.  
 PERMISSIBLE SHAFT RUNOUT TO BE .002 T.I.R.

DASH NO.	"C"	"AD"
750	12.97	6.88
800	13.47	7.38
850	13.97	7.88
900	14.47	8.38
950	14.97	8.88
1000	15.47	9.38
1050	15.97	9.88
1100	16.47	10.38
1150	16.97	10.88

ST	TOLERANCES UNLESS SPECIFIED		DRAWN	VV	09/17/07
	DEC.	INCHES			
	.X	±.1			
	.XX	±.03			
	.XXX	±.005			
F	LABELS ADDED PER ECO	SD 8/12/2019	.XXX		
NO.	REVISION	BY & DATE	CHK	ANG	±1/2"
THIS DRAWING IN DESIGN AND DETAIL IS OUR PROPERTY AND MUST NOT BE USED EXCEPT IN CONNECTION WITH OUR WORK ALL RIGHTS OF DESIGN AND INVENTION ARE RESERVED THIS IS AN ELECTRONICALLY GENERATED DOCUMENT - DO NOT SCALE THIS PRINT			RFP		
			FINISH		
			CAD FILE	035570	SIZE B
			DIST	NLV	DRAWING NO. 035570
					SCALE 1=2
					REF 035537
					FMF
					PREV
					REV. F



TITLE OUTLINE - 180TC FRAME  
 TEFC - "C" FACE  
 MAT'L. GENERAL PURPOSE

VIEW FROM OUTSIDE OF MOTOR AT SWITCH END.

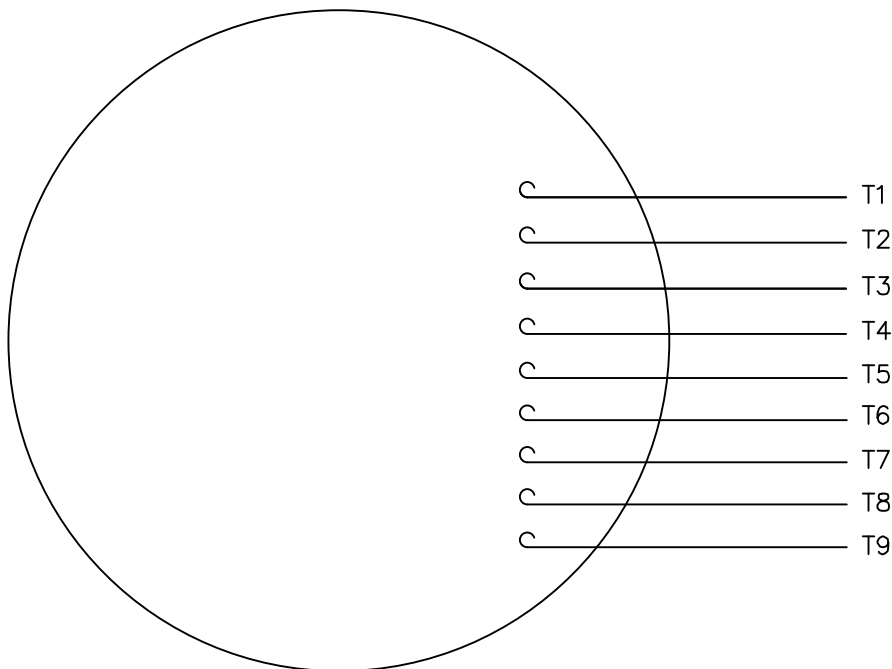

VOLTAGE	L1	L2	L3	JOIN & INSULATE
HIGH	T1	T2	T3	(T4,T7) (T5,T8) (T6,T9)
LOW	T1,T7	T2,T8	T3,T9	T4,T5,T6

		TOLERANCES UNLESS SPECIFIED		DRAWN RDW 04/12/02					
		DEC.	INCHES	CHK					
		.X	±.1	APPD					
		.XX	±.01	SCALE 1=1					
		.XXX	±.005	REF FIG.2-51					
		.XXXX	±.0005	FMF					
NO.	REVISION	BY & DATE	CHK	ANG	FINISH	PREV			
				±1/2"					
THIS DRAWING IN DESIGN AND DETAIL IS OUR PROPERTY AND MUST NOT BE USED EXCEPT IN CONNECTION WITH OUR WORK ALL RIGHTS OF DESIGN AND INVENTION ARE RESERVED THIS IS AN ELECTRONICALLY GENERATED DOCUMENT - DO NOT SCALE THIS PRINT			RFP	04/12/02	CAD FILE	00501001ME	SIZE	DRAWING NO.	REV.
			DIST				A	005010-01ME	



TITLE EXTERNAL WIRING DIAGRAM  
3 PHASE W/O PROTECTOR  
MAT'L. DECAL - 004014

**CERTIFICATION DATA SHEET**

**Model#:** 184TTFW16013 AA      **WINDING#:** T82153 FR 3  
**CONN. DIAGRAM:** 005010.01ME      **ASSEMBLY:** F1 ONLY  
**OUTLINE:** 035570-1050

**TYPICAL MOTOR PERFORMANCE DATA**

HP	KW	SYNC. RPM	F.L. RPM	FRAME	ENCLOSURE	KVA CODE	DESIGN
7 1/2&5	5.6&3.7	3600	3510&2925	184TC	TEFC	L	A

PH	Hz	VOLTS	FL AMPS	START TYPE	DUTY	INSL	S.F	AMB°C	ELEVATION
3	60/50	208- 230/460#190/ 380	19.2- 17.6/8.8&15/7. 5	ACROSS THE LINE	CONTINUOU S	F4	1.0/1.0	40	3300

FULL LOAD EFF: 90.1&90.2	3/4 LOAD EFF: 91.2	1/2 LOAD EFF: 90.8	GTD. EFF	ELEC. TYPE	NO LOAD AMPS
FULL LOAD PF: 88.4&85.5	3/4 LOAD PF: 84.2	1/2 LOAD PF: 75.2	87.5	SQ CAGE IND RUN	6 / 3

F.L. TORQUE	LOCKED ROTOR AMPS	L.R. TORQUE	B.D. TORQUE	F.L. RISE°C
11.2 LB-FT	175 / 87.5	34.6 LB-FT 308	46 LB-FT 409	70

SOUND PRESSURE @ 3 FT.	SOUND POWER	ROTOR WK^2	MAX. WK^2	SAFE STALL TIME	STARTS /HOUR	APPROX. MOTOR WGT
0 dBA	10 dBA	0.221 LB-FT^2	0 LB-FT^2	15 SEC.	2	0 LBS.

**\*\*\* SUPPLEMENTAL INFORMATION \*\*\***

DE BRACKET TYPE	ODE BRACKET TYPE	MOUNT TYPE	ORIENTATION	SEVERE DUTY	HAZARDOUS LOCATION	DRIP COVER	SCREENS	PAINT
C-FACE	STANDARD	ROUND	HORIZONTAL	FALSE	NONE	FALSE	NONE	BLUE (ENAMEL)

BEARINGS		GREASE	SHAFT TYPE	SPECIAL DE	SPECIAL ODE	SHAFT MATERIAL	FRAME MATERIAL
DE	OPE						
BALL	BALL	POLYREX EM	T	NONE	NONE	AISI 1045 (C-240)	ROLLED STEEL
6206	6205						

THERMO-PROTECTORS				THERMISTORS	CONTROL	SPACE /n HEATERS
THERMOSTATS	PROTECTORS	WDG RTDs	BRG RTDs			
NONE	NOT	NONE	NONE	NONE	FALSE	NONE VOLTS

If Inverter equals NONE, contact factory for further information

INVERTER TORQUE: NONE
INV. HP SPEED RANGE: NONE
ENCODER: NONE
NONE NONE
NONE NONE PPR
BRAKE: NONE NONE
NONE P/N NONE
NONE NONE
NONE FT-LB NONE V NONE Hz

\*  
N  
O  
T  
E  
S  
\*

\*\* Subject to change without notice.

Data Sheet

Date: 29-06-2017  
 Customer: \_\_\_\_\_  
 Attention: \_\_\_\_\_  
 Submitted by: FAREEDA DUDEKULA



184TTFW16013

Submittal

Data @ 460 V

Motor Load Data

Load	0%	25%	50%	75%	100%	115%	125%	LR
Current (Amps)	3.0	3.7	5.2	6.9	8.8	10.0	10.9	87.5
Torque (ft-lb)	0.00	2.80	5.6	8.4	11.2	12.9	14.0	34.6
RPM	3600	3579	3556	3535	3510	3,494	3482	0
Efficiency (%)		86.4	90.8	91.2	90.1	89.5	88.5	
P.F. (%)	9.4	55.9	75.2	84.2	88.4	89.7	90.1	0.0

Motor Speed Data

	LR	Pull-Up	BD	Rated	Idle
Speed (RPM)	0	400	3312	3510	3600
Current (Amps)	87.5	80.5	52.5	8.8	3.0
Torque (ft-lb)	34.6	33.5	46.0	11.2	0.00

Information Block

HP	7.5			
Sync. RPM	3600			
Frame	180			
Enclosure	TEFC			
Construction	TFW			
Voltage	3-230/460#190/3V			
Frequency	60 Hz			
Design	A			
LR Code letter	L			
Service Factor	1.15			
Temp Rise @ FL	70 ° C			
Duty	CONT			
Ambient	40 ° C			
Elevation	1,000 feet			
Rotor/Shaft wk <sup>2</sup>	0.22 Lb-Ft <sup>2</sup>			
Ref Wdg	T82153 FR			
Sound Pressure @ 1M	0 dBA			
VFD Rating	NONE			
Outline Dwg	035570-1050			
Conn. Diag	005010.01ME			
Additional Specifications:				
0				
365THFS8036				
EQUIV CKT (OHMS / PHASE)				
R1	R2	X1	X2	Xm
0.0000	0.0000	0.0000	0.0000	0.0000

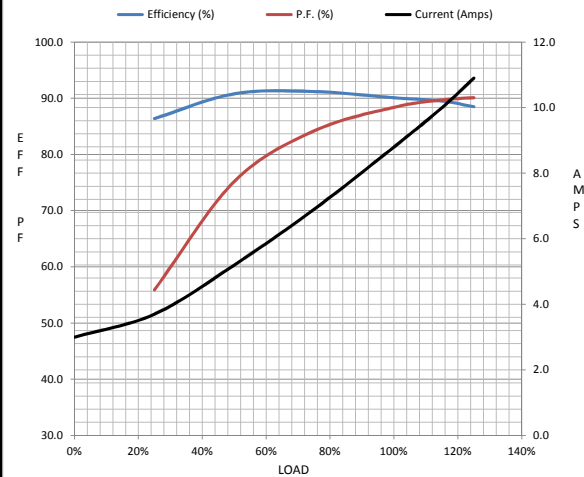

Speed -Torque Curve

